

# Wheel Kit & Spinner Knob Instructions

## Part #: 1004493

Parts List			
ITEM	QTY	PART NUMBER	DESCRIPTION
1	6	1002608	Washer Flat 5/16
2	1	1006016	Washer Aluminum 1 1/8
3	1	1000442	Bolt Nyloc 5/16 x 1.25
4	1	1000504	Nylon Bolt 3/8 x .75
5	1	1000515	MH Spacer .75x.69 Alum - Wheel Kit
6	1	1000514	MH Spacer .75x.27 Alum - Wheel Kit
7	1	1002429	Bolt 3/8 x 2.25
8	1	1001805	Nut Nyloc 3/8
-	1	1002277	Spinner Knob, Bearings and Cap
9	1	----	Knob Handle
10	2	----	Knob Bearing
11	1	----	Knob Cap

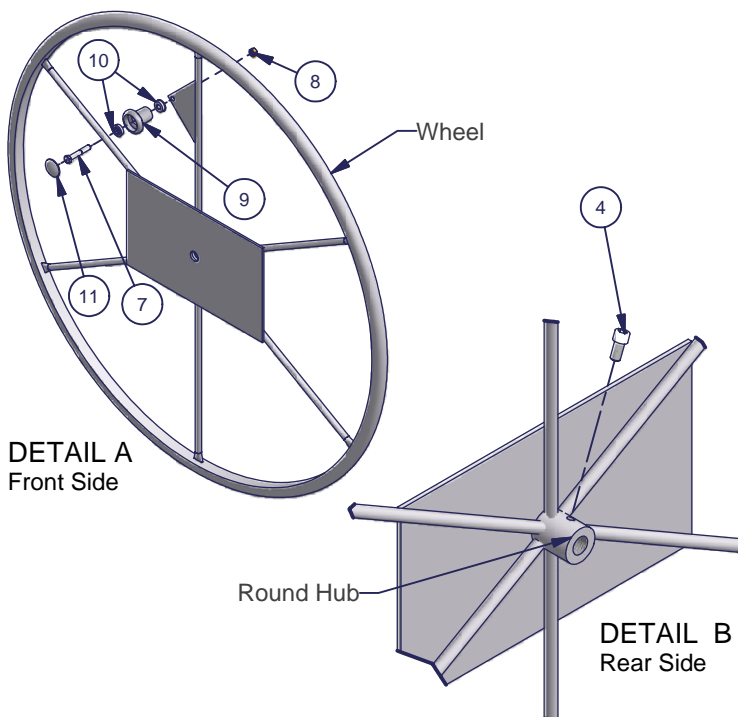

### Assembly:

Pound two Knob Bearings into Knob Handle. Attach Knob Handle with Bearings to the Wheel on the front side - as shown. Secure with one Bolt 3/8 x 2.25 and one Nut Nyloc 3/8. Set Knob Cap into the open face of the Knob Handle and tap with a hammer to indent slightly.

On the rear side of the Wheel thread the Nylon Bolt 3/8 x .75 into the Round Hub enough so that it does not fall off - as shown - Detail B. Once wheel is completely installed on the winch shaft tighten the Nylon Bolt 3/8 x .75 until it contact the winch shaft. This will reduce any oscillating the wheel may experience while operating the winch.

Thread the Wheel clockwise on to shaft of the Winch. You must thread wheel all the way on winch shaft. The wheel hub must be fully against brake pad. Cut a small hole in the middle of the wheel, where the wheel sticker covers the attaching bolt hole.

Prior to securing wheel in place using the Bolt 5/16 x 1 Nyloc, stack a Spacer and/or up to six Washers Flat 5/16. Then place the stack in the bolt hole in the middle of the wheel. The stack should just barely protrude out of the center bolt hole. Remove one Washer Flat 5/16 at a time until the stack just barely protrudes out of the center hole.

**Note:** Small Spacer is for the Whisper Winch, Large Spacer is for the Winch 3000.

Once the correct number of Washers has been determined, secure the wheel in place using the Washer Flat Aluminum 1 1/8 and the Bolt 5/16 x 1 Nyloc - as shown in Detail "C."

**Note:** You should be able to slide a piece of paper in the gap between sticker in the center of the wheel and the washer. The wheel should turn 1/8 to 1/4 turn prior to engaging the Washer Aluminum 1 1/8.

Thread excess cable onto winch hub by turning wheel clockwise. Be sure cable wraps tight and uniformly on hub with each strand lying snugly next to the adjacent strand. Keep tension on the cable by holding it tight when turning the wheel to develop a proper wrap. Do not allow cable to wind up loosely on hub.

### CAUTION

Use a leather glove or other hand protection to avoid cuts when applying cable pressure. Cables wrapping incorrectly will result in rapid cable wear.

