

# SHOREMASTER CANOPY

## OWNERS MANUAL

Canopy Models: 1684, 16108, 2596, 30108, 40108, 40120, 50120,  
20855, 30966, 40966, 401066, 501066, 601066.  
All Hydraulic Lifts

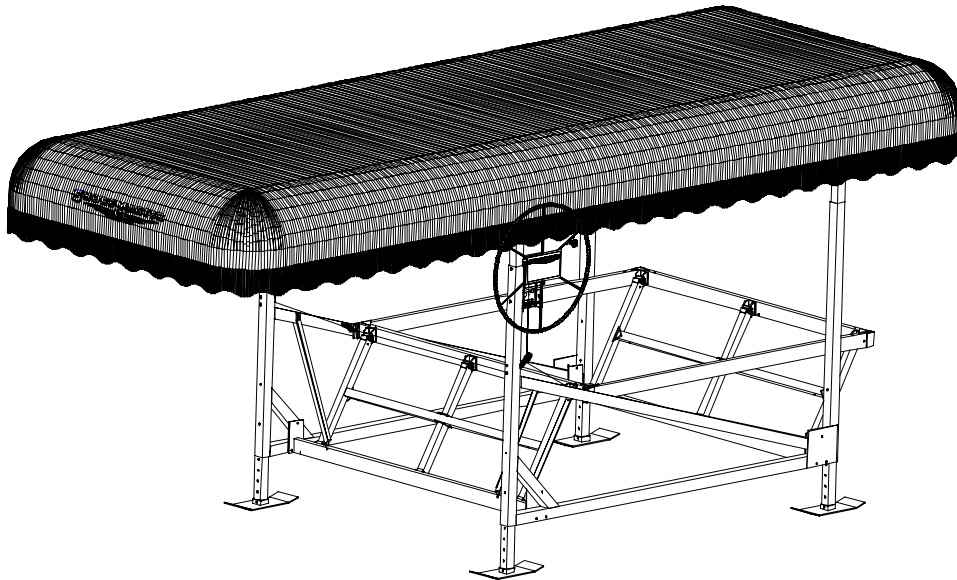

Manufactured by ShoreMaster Inc.  
Revision no. (6) 05/16/2001

Shoremaster Inc.  
1025 International Drive  
Fergus Falls, MN 56538  
1-800-328-8945

## TABLE OF CONTENTS

<u>PAGE</u>	<u>SECTION</u>
2	<b><u>Introduction</u></b> - General overview of canopy.
2	<b><u>Warnings and Safety</u></b> - Important information concerning safe use of canopy.
3	<b><u>Parts List</u></b> - Detailed description and pictures of components used in assembly of canopy.
4-8	<b><u>Assembly and Installation</u></b> - Instruction for canopy assembly and installation on boat lift.
9	<b><u>Operation and Use</u></b> - Proper use of canopy.
10	<b><u>Removal and Storage</u></b> - Required removal and storage needs.
11	<b><u>Service</u></b> - Proper service procedures.

## INTRODUCTION

The ShoreMaster canopy is used with ShoreMaster cantilever and vertical boat lifts. Many similarly designed canopy models are made by ShoreMaster. A canopy model may fit more than one boat lift model. A ShoreMaster canopy may fit many non-ShoreMaster brands. Contact ShoreMaster or an authorized dealer for more information.

**NOTE: Canopy warranty applies only if installed with a genuine ShoreMaster manufactured frame and vinyl.**

This product provides your boat with protection from the sun and rain. A canopy is a simple and time saving alternative to cumbersome mooring covers, provided your boat is properly raised and under your canopy.

The information in this manual is not all inclusive and does not cover all unique situations. Questions about assembly, installation, use, or suitability of this product can be answered by contacting an authorized ShoreMaster dealer or ShoreMaster toll-free **1-800-328-8945**.

## WARNINGS AND SAFETY

Your SAFETY is the most important issue related to this product. It is critical that all assemblers, installers, and users read and fully understand the warnings and safety information contained throughout this manual before using this product.

### Safety Instructions

- ✂ Use proper **protective clothing** and **safety glasses** when assembling, installing, removing, or servicing this product!
- ✂ Do not assemble or use this product if items are missing or damaged!
- ✂ This product requires two or more persons to safely assemble and install.
- ✂ A canopy with vinyl attached is a wind hazard! Do not leave vinyl on frame unless canopy is secured to a properly installed boat lift.
- ✂ Canopy frame and vinyl cannot support excess weight. Do not stand on, hang from or set heavy objects on canopy.
- ✂ Inspect all canopy bolts, nuts, cords and hooks every three months for loose or damaged parts. Tighten or replace parts as needed.

# CANOPY PARTS LIST

Before assembly, identify each part. Remove parts from boxes, bags and bundles. **Mark each item with the proper Part letter** (indicated in the left-hand column of this page). This will confirm that all parts are here before beginning assembly and will allow you to easily follow the assembly instructions.

<u>Part</u>	<u>Quantity</u>	<u>Description</u>
<b>A</b>	(2)	<u>Frame Sides</u> - Both the same
<b>B</b>	(2)	<u>Frame Ends</u> - Both the same
<b>C</b>	(0 or 4)	<u>Drilled Legs</u>
<b>D</b>	(0 or 4)	<u>Adjustable sliding Leg</u>
<b>E</b>	(1)	<u>Vinyl Cover</u>
<b>F</b>	(1)	<u>Bag of Bungee Cords</u> -
<b>G</b>	(1)	<u>Bolt Bag</u> - See next column (amounts depend on model)

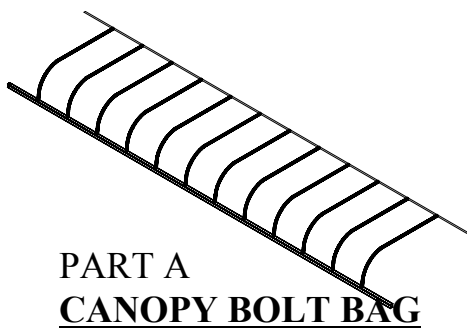

**PART A**  
**CANOPY BOLT BAG**

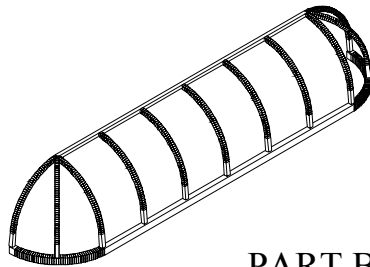

**PART B**

**Model 1684**

- 4- 5/16" x 2 1/2" Carriage Bolts
- 6 - 5/16" x 2-1/2" Hex Bolts
- 10- 5/16" Nuts
- 16- 5/16" Flat Washers
- 3- 3/8" x 2 3/4" Hex Bolts
- 3- 3/8" Nuts
- 6- 3/8" Washers

**Models 2596 & 20855**

- 4- 5/16" x 2 1/2" Carriage Bolts
- 7 - 5/16" x 2-1/2" Hex Bolts
- 11- 5/16" Nuts
- 18- 5/16" Flat Washers
- 3- 3/8" x 3" Hex Bolts
- 3- 3/8" Nuts
- 6- 3/8" Washers

**Models 401066**

- 40108, 40120, 40966**
- 4- 5/16" x 2 1/2" Carriage Bolts
  - 8 - 5/16" x 2-1/2" Hex Bolts
  - 12- 5/16" Nuts
  - 20- 5/16" Flat Washers
  - 3 - 3/8" x 3 1/2" Hex Bolts
  - 4 - 3/8" Nuts
  - 7 - 3/8" washers
  - 1 - 3/8" x 1" Carriage Bolt

**Model 16108**

- 4- 5/16" x 2 1/2" Carriage Bolts
- 7-5/16" x2-1/2" Hex Bolts
- 11- 5/16" Nuts
- 18- 5/16" Flat Washers
- 3- 3/8" x 2 3/4" Hex Bolts
- 3- 3/8" Nuts
- 6- 3/8" Washer

**Models 50120 & 701066**

- 4- 5/16" x 2 1/2" Carriage Bolts
- 9 - 5/16" x 2-1/2" Hex Bolts
- 13- 5/16" Nuts
- 22- 5/16" Flat Washers
- 3- 3/8" x 4" Hex Bolts
- 3- 3/8" Nuts
- 6- 3/8" Flat Washers

**Model 501066**

- 4- 5/16" x 2 1/2" Carriage Bolts
- 9 - 5/16" x 2-1/2" Hex Bolts
- 13- 5/16" Nuts
- 22- 5/16" Flat Washers
- 3- 3/8" x 3-1/2" Hex Bolts
- 4- 3/8" Nuts
- 7- 3/8" Flat Washers
- 1 - 3/8" x 1" Carriage Bolt

**Models 30108 & 30966**

- 4- 5/16" x 2 1/2" Carriage Bolts
- 7 - 5/16" x 2-1/2" Hex Bolts
- 11- 5/16" Nuts
- 18- 5/16" Flat Washers
- 3- 3/8" x 3 1/2" Hex Bolts
- 4- 3/8" Nuts
- 7- 3/8" Flat Washers
- 1 - 3/8" x 1" Carriage Bolt

**Models Hydraulic Lifts**

- 4 - 5/16" x 2-1/2" Carriage Bolts
- 9 - 5/16" x 2-1/2" Hex Bolts (Quantity depends on canopy size)
- 13 - 5/16" Nuts (Quantity depends on canopy size)
- 22 - 5/16" Flat Washers (Quantity depends on canopy size)
- 3 - 3/8" x 3-1/2" Hex Bolts
- 1 - 3/8" x 1" Carriage Bolt
- 4 - 3/8" Nuts
- 7 - 3/8" Flat Washers

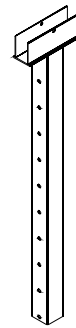

**PART C**  
**ASSEMBLY AND INSTALLATION**



**PART D**

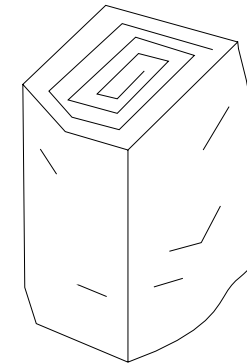

**PART E**

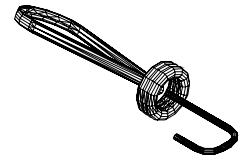

**PART F**

**\*Two or more people are needed to safely assemble and install canopy.**

**\* On all 3/8" bolts, use a washer under the bolt head & nut.**

**#1** Place two A parts (frame sides) in position as shown.

**#2** Hold A parts together as shown. Next, slide one part B (frame end) into exposed ends of A parts as shown. Repeat this on the opposite end with other part B.

## CAUTION

The canopy ends (B parts) are not held on with bolts. They are held in place by friction and secured when attaching the vinyl. They could fall out when moving the frame (without the vinyl in place) and injure you! Secure ends in place for added security.

**#3** Bolt A parts together as shown using 5/16" x 2 1/2" hex bolts, 5/16" nuts & 5/16" washers. There are 7, 8 or 9 used depending on model.

**Note:** If the bolt holes along the two A parts do not line up perfectly, first try to improve the alignment by pushing down on the spine where A parts meet. If necessary, it will not damage the canopy to drill out the bolt holes from one side using a 3/8" drill bit.

**Note:** If you have a Hydraulic lift skip step #4.

**Note:** If you have four Slider Legs Skip to step #6.

**#4** Remove blue lift caps from boat lift uprights. Lower boat lift rack to full down position and make sure there is no weight on the lift. Loosen bolts and nuts holding boat lift winch in place and temporarily remove the winch from the lift upright. These two bolts and nuts are reattached after part C is in place!

**#5** Attach four C parts (legs) by sliding them into exposed opening in lift uprights. Each part C must be bolted in place at same level. Bolt in place using your 3/8" hex bolts, 3/8" nuts & 3/8" washers. The bolt lengths will vary depending on your model.

- For non-hydraulic lifts, use one bolt, nut and washers for three of four C parts (reuse existing two bolts and nuts for part C attached to winch upright). Reattach the boat lift winch with the C part (canopy leg) in desired position.

**Note: Hydraulic lift uses four 3/8" bolts, nuts and washers to attach C parts (canopy leg).**

**Note:** The level your canopy legs are set at determines how high your canopy is compared with your boat lift. Canopy should be positioned as low as possible, while still allowing you access to boat from dock, when your boat is lowered into water.

- Estimate the distance to fully raise boat out of water (up and under your canopy) without interference.
- Proper canopy positioning also requires boat lift to be adjusted so lift is placed at proper dockside height.

**#6** Insert (one) 3/8" x 1" carriage bolt in the lift leg from the inside and attach loosely with (one) 3/8" washer and (one) 3/8" brass nut (as shown).

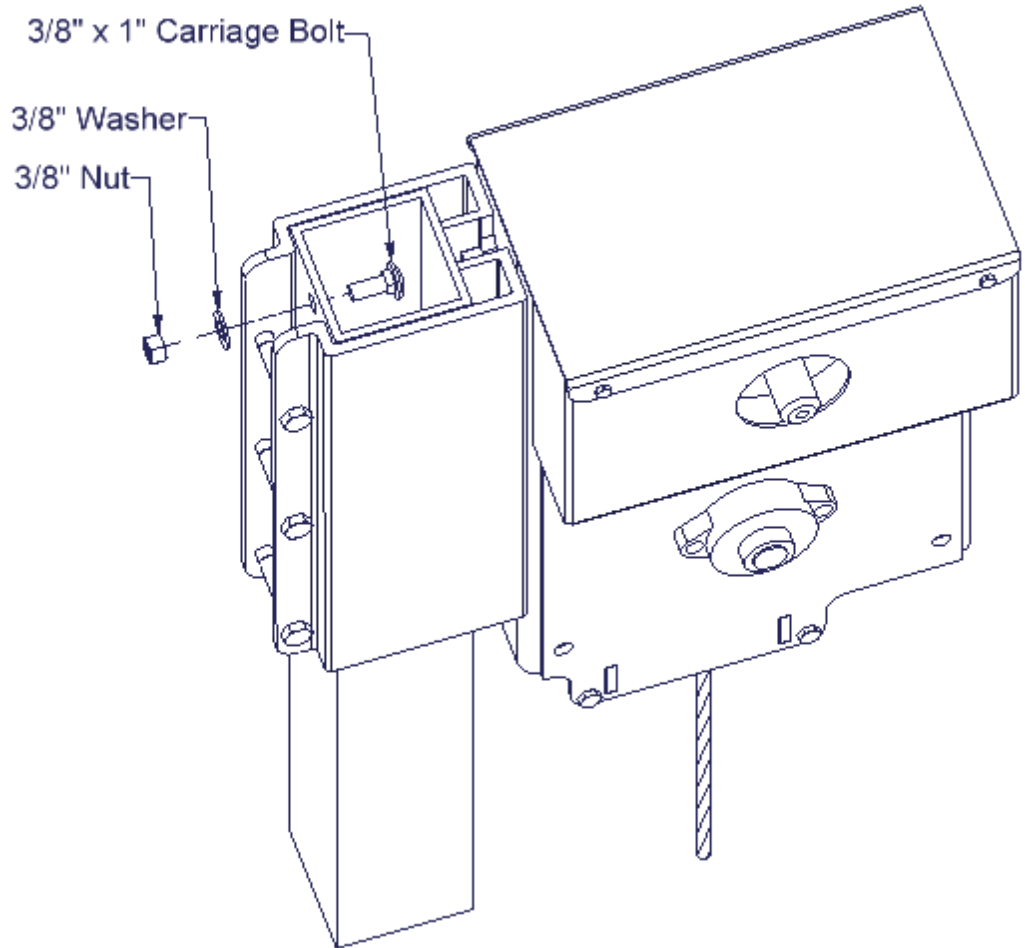

**#7** Slide the slotted canopy leg over the carriage bolt and tighten nut at desired height (as shown).

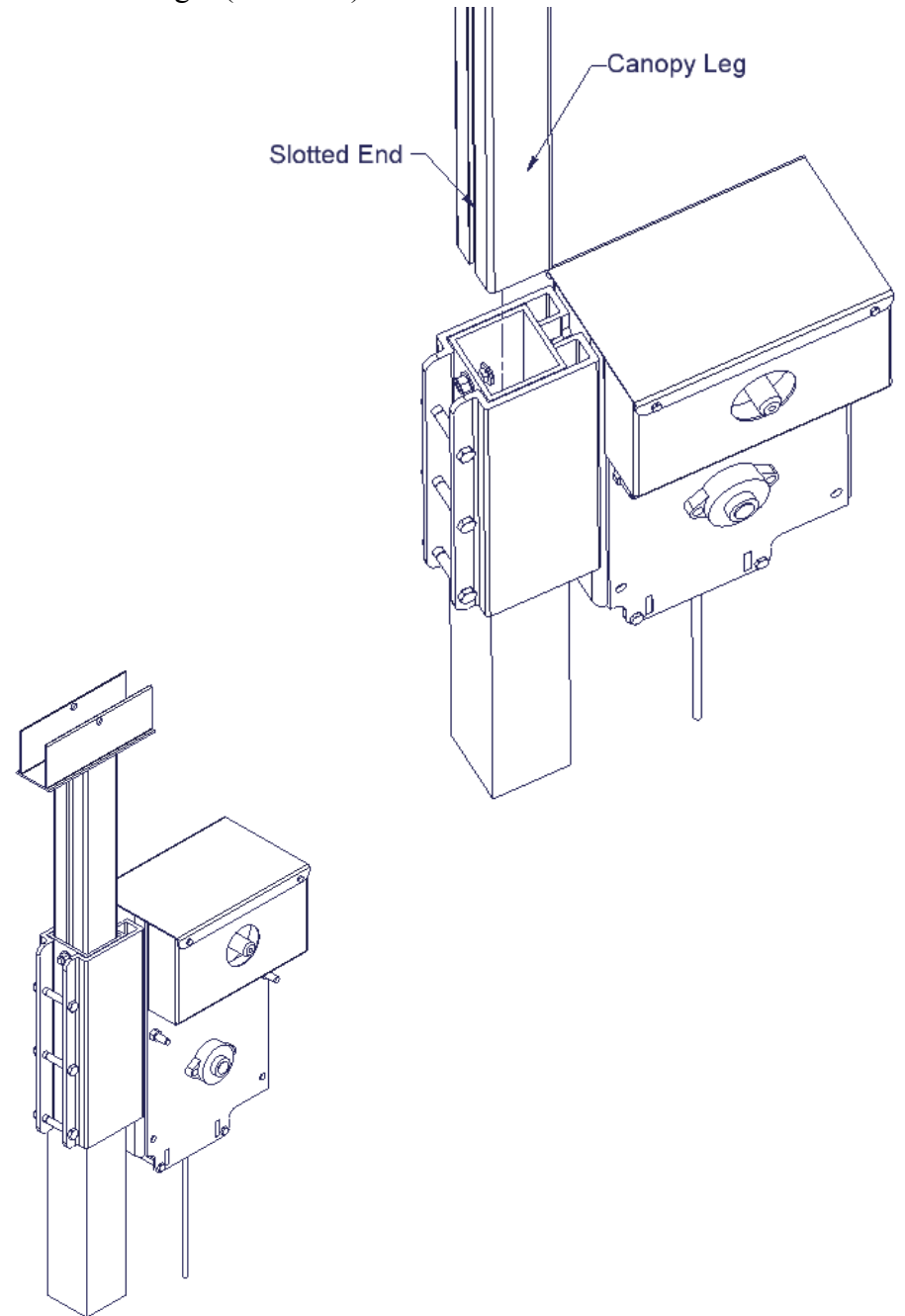

**#8** Place the assembled canopy frame into the exposed U-shaped channels (saddles) of the already attached C or D parts. Slide the frame in position.

**#9** Place part E (vinyl canopy cover) over canopy frame. Position vinyl cover so it fits equally over the entire frame.

**Note:** Position D-rings away from canopy legs. You won't get a uniform attachment of bungee cords to frame if a D-ring is lined up with a canopy leg.

**Note:** Frame position should match estimated boat and motor position. Most boats are positioned forward in lift to provide proper balance and support. Usually 1 - 4 feet of canopy frame extends past rear of lift and the remaining 7 - 15 feet of frame extends past front of lift.

**#10** Bolt the frame in position with four 5/16" carriage bolts, 5/16" nuts & 5/16" washers. One attached to each C or D as shown. Make sure head of carriage bolt is facing to the outside of the lift (as shown).

## CAUTION

Attach nuts and bolts holding canopy frame to canopy legs very tight! Not securing this properly could result in frame sliding or falling out of position resulting in damage to canopy, boat or lift. A falling or slipping canopy could cause injury to anyone in area!

## CAUTION

Vinyl canopy cover is a hazard if exposed to high winds! Do not attach vinyl to canopy frame if wind affects your ability to safely fasten. Do not leave vinyl unattended on frame when attaching.

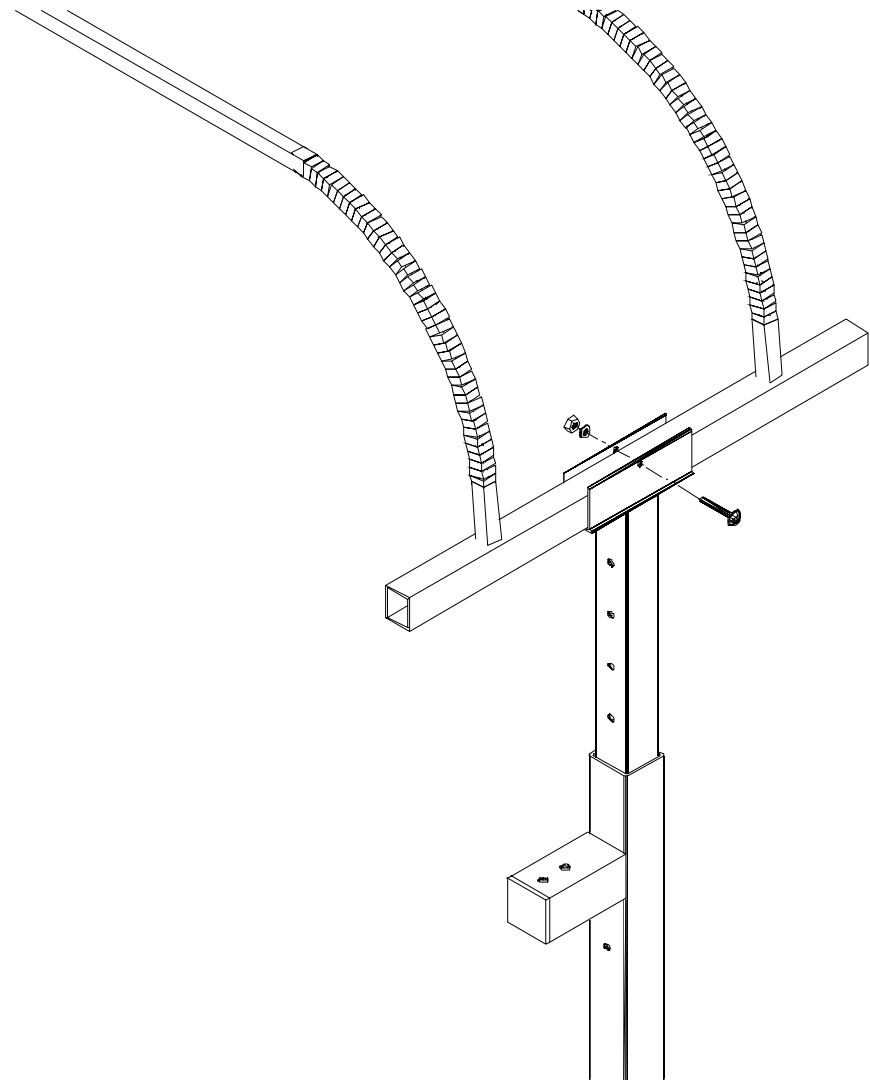

## CAUTION

Stretching and attaching bungee cords requires strength and proper balance. Do not let go of bungee cords when under tension. An eye injury or other bodily injury could occur. Always wear proper protective clothing and safety glasses!

**#11** Be sure the frame is in the desired position before proceeding.

**#12** Secure the vinyl to the frame with the individual bungee cords. Take the bungee cord and slide the cord through the grommet or D-ring, take the hook of the bungee cord and slide it through the end of the bungee cord (see view B), then take the hook of the bungee cord and attach it to the canopy bow directly above the grommet or D-ring (views A&C). Use a bungee cord for every grommet or D-ring.

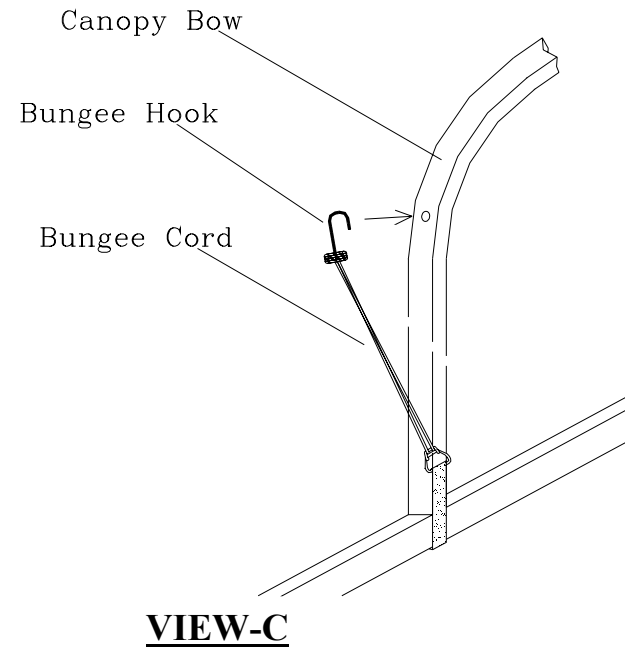
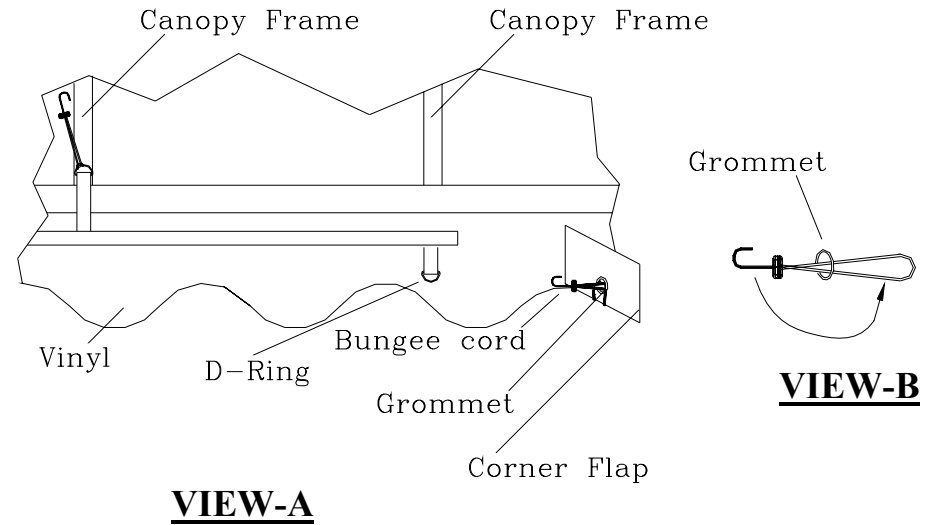

## OPERATION AND USE

**#1** Canopy provides best protection when your boat is positioned up and into the frame.

### CAUTION

Severe or strong winds can pick up a boat, lift and canopy. This would cause damage to equipment and injury to anyone in its path. Position your boat up within canopy frame to provide protection and reduce chance of severe winds circulating inside canopy.

### CAUTION

Do not raise boat lift up past recommended lift height to position boat higher in canopy. If over raising appears necessary to properly position boat, remove lift and canopy from water and adjust canopy legs down to desired level.

### CAUTION

Do not leave vinyl on canopy frame unless boat lift is firmly in place. Sink lift leg pads into lake bottom. Settling is helped by leaving boat on lift for several days and covering lift leg pads with lake bottom soil. These steps provide a suction effect.

### CAUTION

**Secure boat lift with canopy to lake bottom** or a strong dock if you have a hard lake bottom (little or no soil), experience violent winds, will not have your boat in lift during strong winds, or **if you are using a boat under 1400 lb.** You can use augers or trailer house anchors to provide needed additional security.

## **REMOVAL AND STORAGE**

**#1** The canopy vinyl must be removed when boat lift is not properly secured in water or if not being used regularly. You can remove vinyl by detaching hooks.

### **CAUTION**

Stretching and removing bungee cords requires strength and proper balance. Do not let go of bungee cords when under tension. An eye injury or other bodily injury could occur. Always wear proper protective clothing and safety glasses!

### **CAUTION**

Canopy frames and vinyl's cannot support extra weight. Remove vinyl if you experience snowfall. Not removing vinyl and allowing accumulation of snow on canopy could damage frame and vinyl!

**#2** Store vinyl in warm dry place. Be sure vinyl is clean and dry before folding or rolling up for storage.

### **CAUTION**

Store canopy vinyl in a warm dry place to avoid cracks from freezing. Do not fold or handle vinyl if temperature is below 45 degrees Fahrenheit, cracking could occur.

## **SERVICE**

**#1** A properly maintained canopy will require little service to the frame or structure. A canopy vinyl used under normal circumstances should provide 5 - 10 years of use before needing replacement.

- Inspect all canopy bolts, nuts, cords and hooks every three months for loose or damaged parts. Tighten or replace parts as needed.
- Check other parts once a year for cracks, breaks or wear. Replace parts as needed.
- If damage occurs to any part, replaced damaged item before resuming use.

### **CAUTION**

Do not use chemicals or abrasives to clean your canopy vinyl. Using chemicals or abrasives will destroy your vinyl's sun and mold protection. This will result in premature aging and decay of your vinyl. Use a soft dish soap and pressurized water to clean your vinyl.



Name: \_\_\_\_\_  
Address: \_\_\_\_\_  
City: \_\_\_\_\_ State: \_\_\_ Zip Code: \_\_\_\_\_  
Telephone: (     ) \_\_\_\_\_  
E-Mail: \_\_\_\_\_

Date of Purchase: \_\_\_\_\_

Place of Purchase: \_\_\_\_\_

• Please forward complimentary copy of our ShoreMaster Products DVD  (please check)

Type of Product Purchased

- Wheel-A-Dock
- Standing Dock
- Floating Poly Dock
- Vertical Lift
- Cantilever Lift
- Hydraulic Lift
- Canopy Frame
- Canopy Vinyl
- Shoreport

Model: \_\_\_\_\_

HAVE YOU PREVIOUSLY OWNED A SHOREMASTER PRODUCT: • YES • NO

HOW DID YOU FIRST HEAR OF SHOREMASTER? • BOAT SHOW  
• NEWSPAPER • TV/RADIO • DEALER • FRIEND/RELATIVE • OTHER

WHY DID YOU CHOOSE SHOREMASTER? (YOU MAY CHOOSE MORE THAN ONE)  
• SHOREMASTER'S REPUTATION • DEALER RECOMMENDATION • PRICE  
• PRODUCT AVAILABILITY • SPECIAL FEATURES & ACCESSORIES

DID YOU RECEIVE PRODUCT • ASSEMBLED • UNASSEMBLED

WAS THE PRODUCT INSTALLED BY • DEALER • SELF • OUTSIDE LABOR

ARE YOU LIKELY TO PURCHASE ADDITIONAL WATER FRONT EQUIPMENT: • YES • NO

ARE YOU LIKELY TO CHOOSE SHOREMASTER PRODUCTS: • YES • NO

ADDITIONAL COMMENTS: \_\_\_\_\_

Return to: ShoreMaster  
P.O. Box 358  
Fergus Falls, MN 56537

